

MC_425A/W, MF_425A/W, _P425A/W Ice Machines - 230 V 50 Hz, 220 V 60 Hz

Installation Guide

Please visit <https://www.follettice.com/technicaldocuments>
for the Operation and Service manual for your unit.

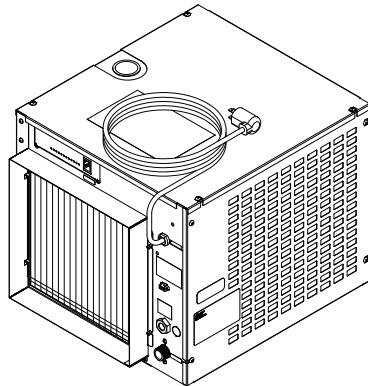

MCC425A/W_S
MCE425A/W_S
ER425A/W

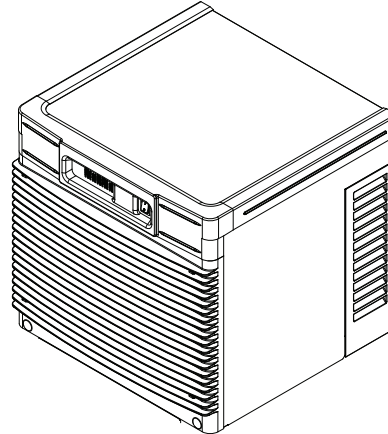

MCC425A/W_T
MCE425A/W_T
MFC425A/W_T
MFE425A/W_T

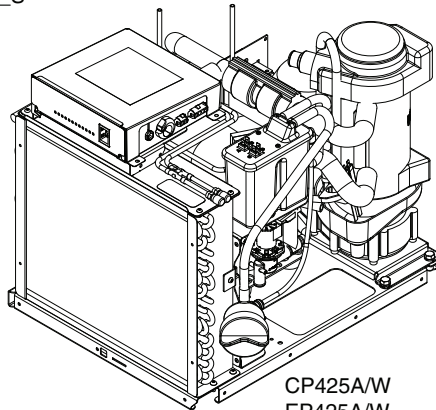

CP425A/W
EP425A/W

Welcome to Follett

Follett equipment enjoys a well-deserved reputation for excellent performance, long-term reliability and outstanding after-the-sale support. To ensure that this equipment delivers that same degree of service, review this guide carefully before you begin your installation.

Should you have need technical help, please call our Technical Service group at (877) 612-5086 or (610) 252-7301.

Please have your model number, serial number and complete and detailed explanation of the problem when contacting Technical Service.

Getting Started

After uncrating and removing all packing material. Inspect the equipment for concealed shipping damage. All freight is to be inspected upon delivery. If visible signs of damage exist, please refuse delivery or sign your delivery receipt "damaged." Follett Customer Service must be notified within 48 hours. Wherever possible, please include detailed photos of the damage with the original packaging so that we may start the freight claim process.



CAUTION!

- Do not tilt unit further than 30° off vertical during uncrating or installation.
- Dispenser bin area contains mechanical, moving parts. Keep hands and arms clear of this area at all times. If access to this area is required, power to unit must be disconnected first.
- This appliance is not suitable for installation in an area where a water jet could be used.
- This appliance must not be cleaned by a water jet.
- User maintenance should not be done by children.
- Follett recommends a Follett water filter system be installed in the ice machine inlet water line (standard capacity #00130229, high capacity #00978957, carbonless high capacity #01050442).
- Prior to operation clean the dispenser in accordance with instructions found in this manual.
- Do not block air intake or exhaust.
- This appliance should be permanently connected by a qualified person in accordance with application codes.
- A qualified person shall provide a readily accessible disconnect device incorporated into the fixed wiring.
- If the supply cord is damaged, it must be replaced by the manufacturer, its service agent or similarly qualified persons in order to avoid a hazard.
- This appliance can be used by children aged 8 years and above and persons with reduced physical, sensory, or mental capabilities, or lack of experience and knowledge if they have been given supervision or instruction concerning use of the appliance in a safe way and understand the hazards involved. Children should be supervised to ensure that they do not play with the appliance.
- This appliance is designed for commercial use.
- **WARNING!** To avoid a hazard due to instability of the appliance, it must be fixed in accordance with the instructions.
- Warranty does not cover exterior or outside installations.
- To reduce risk of shock, disconnect power before servicing.
- Connect to potable water supply only.
- Ice is slippery. Maintain counters and floors around dispenser in a clean and ice-free condition.
- Ice is food. Follow recommended cleaning instructions to maintain cleanliness of delivered ice.

Specifications

Electrical

- Each ice machine and dispenser requires a separate circuit with electrical disconnect within 10 ft (6 m).
- Equipment ground required.
- Standard electrical – 230 V, 50 Hz, 1 phase or 220 V, 60 Hz, 1 phase
- Connect to a dedicated circuit.
- Maximum ice machine amperage – 5.5A.
- Cord provided on ice machine.

Plumbing

- 3/8" FPT water inlet
- 3/4" MPT drain
- 3/8" FPT condenser inlet (water-cooled condenser only)
- 3/8" FPT condenser drain (water-cooled condenser only)

Notes:

- Slope to drain of 1/4" per foot (20 mm per 1 m run) with a 1/2" min. is recommended.
- Water shut-off recommended within 10 feet (3 m), drain to be hard piped and insulated.
- Separate drains for ice machine and condenser. To prevent back flow, do NOT connect drains.
- Follett recommends a Follett water filter system be installed in the ice machine inlet water line (standard capacity #00130229, high capacity #00978957, carbonless high capacity #01050442).

Ambient

Air temperature*	100 F/38 C max.	50 F/10 C min. (best performance below 80 F/27 C)
Water temperature†	90 F/32 C max.	45 F/10 C min. (best performance below 70 F/21 C)
Water pressure	70 psi max. (482 kPA)	10 psi min. (68 kPA)
Condenser water temperature	90 F/32.2 C max.	45 F/7.2 C min
Condenser water pressure	125 psi (862 kPA) max.	10 psi (68 kPA) min.

* Ambient air temperature is measured at the air-cooled condenser coil inlet.

† Ambient water temperature is measured in the ice machine reservoir.

Water usage (water-cooled condenser only)

- 0.25 gpm (0.95 L/m) @ 50 F (10 C)
- 0.5 gpm (1.90 L/m) @ 70 F (21 C)
- 1.25 gpm (4.73 L/m) @ 90 F (32 C)

Shipping weight

- 73 kg (160 lb)

Technical specifications

Refrigeration pressure data

- Water regulating valve is factory set at 300 ±10 PSIG (2068.4 ± 69 kPA) head pressure.
- Readings within 10% of table values should be considered normal.

Compressor data

Air-cooled										
Ambient air temperature	60 F/15.6 C		70 F/21.1 C		80 F/26.7 C		90 F/32.2 C		100 F/37.8 C	
	220 V	230 V	220 V	230 V	220 V	230 V	220 V	230 V	220 V	230 V
Amperage	2.65	2.25	2.77	2.36	2.89	2.46	3.01	2.57	3.13	2.68
High-side pressure (psi)	219	199	256	233	293	266	330	306	367	346
Low-side pressure (psi)	28	29	30	31	33	33	35	36	38	38

Water-cooled										
Condenser water temperature	60 F/15.6 C		70 F/21.1 C		80 F/26.7 C		90 F/32.2 C		100 F/37.8 C	
	220 V	230 V	220 V	230 V	220 V	230 V	220 V	230 V	220 V	230 V
Amperage	2.8	2.4	2.9	2.5	2.9	2.5	2.9	2.5	3.0	2.6
High-side pressure (psi)	290	290	291	291	292	292	292	293	293	294
Low-side pressure (psi)	31	32	31	32	32	33	32	34	33	34

Locked rotor amps 220 V: 19.6A

230 V: 18.2A

Condenser water usage: @70 F/70F: 0.26 gal/min

@90 F/70F: 0.56 gal/min

Gearmotor data	220 V/60 Hz	230 V/50 Hz
Gearmotor current	1.0A (nominal)	1.3A (nominal)
Locked rotor amps	6.8A	6.8A

Refrigeration system

Important: All service on refrigeration system must be performed in accordance with all federal, state and local laws that pertain to the use of refrigerants. It is the responsibility of the technician to ensure that these requirements are met.

R425 ice machine charge specifications

Model	Charge	Refrigerant type
E425 230 V, 50 Hz (air-cooled)	13 oz	R449A
C425 220 V, 60 Hz (air-cooled)	15 oz	R404A
C/E425 water-cooled	9 oz	R404A

Dimensions and clearances

- Entire front of ice machine must be clear of obstructions/connections to allow removal.
- 12" (30.5 cm) clearance above ice machine for service.
- 6" (15.3 cm) minimum clearance between exhaust side of ice machine and any adjacent equipment.
- MCE425A and ER425A – 18" (45.7 cm) minimum, 10 ft (3 m) maximum clearance between discharge and air intake grilles.

MCE425A/W_T MFE425A/W_T

Front view — top mount

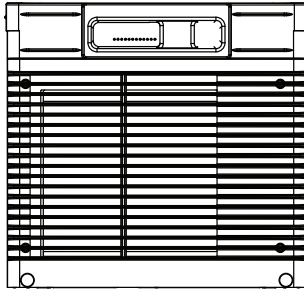

Side view — top mount

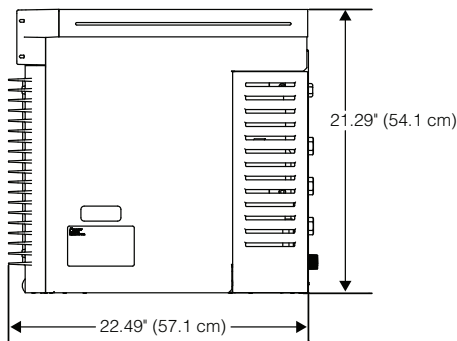

Back view — top mount

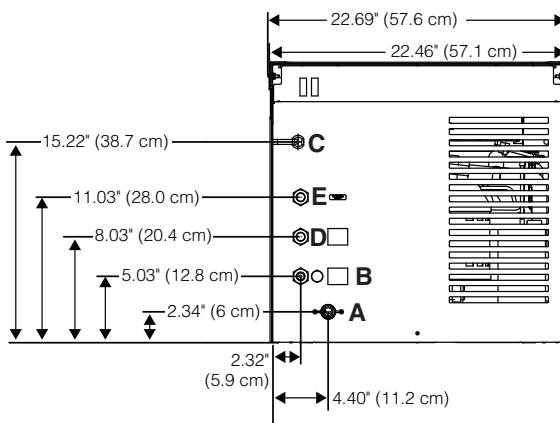

MCE425A/W_S ER425A/W

Front view — air-cooled

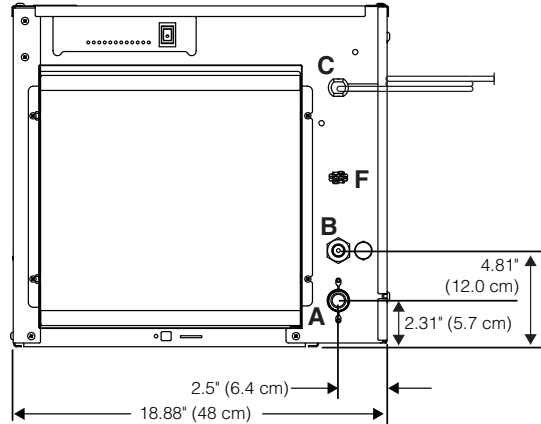

Front view — water-cooled

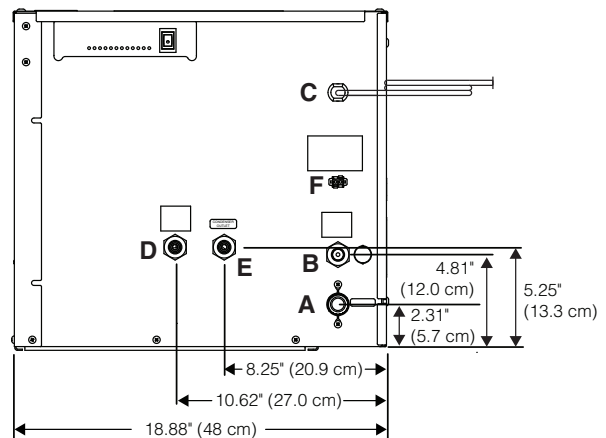

Side view — air-cooled and water-cooled

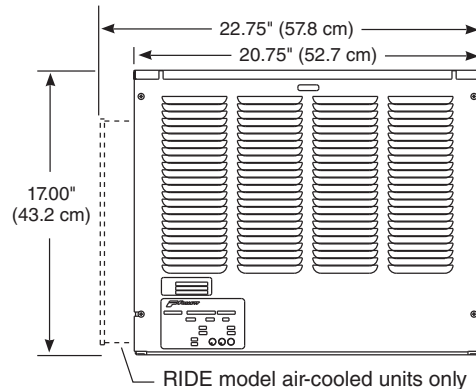

A – 3/4" MPT drain
B – 3/8" FPT water inlet
C – Electrical cord

D – 3/8" FPT condenser inlet
E – 3/8" FPT condenser drain
F – Bin signal connection (DO NOT APPLY VOLTAGE!)

Cleaning

Follett ice machines and dispensers, and their associated cleaning and sanitizing procedures, are designed for use with potable water sources. The presence, or suspected presence, of infectious agents may call for additional measures, including the replacement of components and more comprehensive disinfection measures. Follett recommends that these cleaning and sanitizing procedures be reviewed with the appropriate infectious agent subject matter experts to assure complete remediation.

Periodic cleaning of Follett's ice machine system is required to ensure peak performance and delivery of clean, sanitary ice. The recommended cleaning procedures that follow should be performed at least as frequently as recommended and more often if environmental conditions dictate.

Cleaning of the condenser can usually be performed by facility personnel. Cleaning of the ice machine system should be performed by your facility's trained maintenance staff or a Follett authorized service agent. Regardless of who performs the cleaning, it is the operator's responsibility to see that this cleaning is performed according to the schedule below. Service problems resulting from lack of preventive maintenance will not be covered under the Follett warranty.

Recommended cleaning intervals*

Maestro Plus	Frequency
Drain Line	weekly
Drain Pan/Drip Pan	weekly
Exterior, Water Station Tube	as needed
Condenser	monthly (air-cooled only)
Ice Machine	semi-annually
Transport Tube	semi-annually

* Ice machine must be cleaned prior to start-up.

Weekly

The exterior may be cleaned with a stainless cleaner such as 3M™ Stainless Steel Cleaner & Polish or equivalent.

Monthly

Condenser (air-cooled ice machine only)

1. Use a vacuum cleaner or stiff brush to carefully clean condenser coils of lint and debris to ensure optimal performance.
2. When reinstalling counter panels in front of RIDE® model ice machines, be sure that ventilation louvers line up with condenser air duct.

Semi-Annually (more often if conditions dictate)

- A cleaning procedure should always include both the ice machine and bin/dispenser.
- Icemaking system can be cleaned in place.

Cleaning Tool Checklist

- (1) 1.5 gallon (or larger) plastic bucket
- (2) clean cloths
- Sanitary gloves
- Safety glasses
- SafeCLEAN™ Plus ice machine cleaner
- (2) SaniSponge™ (PN 00131524 - single sponge)



CAUTION!

- Wear rubber gloves and safety goggles (or face shield) when handling SafeCLEAN Plus solution.
- Use only Follett approved cleaners.
- Do not use solvents, abrasive cleaners, metal scrapers or sharp objects to clean any part of the dispenser.

SafeCLEAN Plus Solution: Follow the directions on the SafeCLEAN Plus packaging to mix 1 gal. (3.8 L) of Follett SafeCLEAN Plus solution. Use 100 F (38 C) water.

Cleaning Procedure

Note: Check drains and drain cup to ensure they are open and flowing freely.

1. If ice machine was running recently, ensure that the evaporator is completely free of ice before proceeding. If there is ice in the evaporator, complete steps 2-7 using only hot water to remove the ice, then begin Cleaning Procedure again.
2. Remove front or top cover.
3. Disconnect bin signal cable from ice machine electrical box.
4. Press **CLEAN** switch. The **MAINTENANCE** light will turn on and the machine will drain. Wait for the **LOW WATER** light to turn on.
5. Remove lid from cleaning cup and fill (about 1 quart) until SafeCLEAN Plus solution completely fills the reservoir. Place lid back on cup.
6. **CLEANER FULL** light will turn on and machine will start cleaning cycle then rinse three times; this process takes approximately 15 minutes.
7. When machine is finished cleaning, the **MAINTENANCE** light will turn off.
8. Remove top bearing insulation. Loosen Phillips-head screw on nozzle connected to evaporator. Remove nozzle from evaporator side only, leave other side of nozzle connected to transport tube.
9. Soak one SaniSponge in remaining SafeCLEAN Plus solution.
10. Insert the sponge soaked in SafeCLEAN Plus solution into nozzle then insert a dry sponge into the nozzle.
11. Replace nozzle onto evaporator and tighten screw. Ensure drain is connected to reservoir and vent tubes are connected to evaporator drain pan. Replace top bearing insulation.
12. Reconnect bin signal cable. Wait for ice to push sponges through transport tube.
13. Collect sponges from ice storage bin.
14. Replace front or top cover.
15. After 10 minutes, dispense all ice and discard.
16. Clean the dispenser/bin.

Exterior Cabinet

Clean stainless steel panels with stainless steel cleaner.

Electrical system



ATTENTION!

To prevent circuit breaker overload, wait 15 minutes before restarting this unit. This allows the compressor to equalize and the evaporator to thaw.

Normal control board operation

The PC board indicator lights provide all the information necessary to determine the machine's status. Green indicator lights generally represent “go” or normal operation; Yellow indicators represent normal off conditions; Red indicators generally represent alarm conditions, some of which will lock the machine off.

A flashing green light labeled POWER indicates power to the machine. All other normal operation status indicators are covered as follows:

Ice machine disposition	Operating conditions
Legend: ● ON ○ OFF ◐ ON or OFF ◑ FLASHING	
1. Ice machine is making ice. CLEANER FULL ○ DRAIN CLOG ○ HI PRESS ○ HI AMPS ○ SERVICE ○ MAINT/CLEAN ○ LOW WATER ○ TIME DELAY ○ SLEEP CYCLE ○ MAKING ICE ● LOW BIN ● POWER ON ◑	1. Normal running.
2. Ice machine is not making ice. CLEANER FULL ○ DRAIN CLOG ○ HI PRESS ○ HI AMPS ○ SERVICE ○ MAINT/CLEAN ○ LOW WATER ○ TIME DELAY ● SLEEP CYCLE ○ MAKING ICE ○ LOW BIN ◐ POWER ON ◑	2. Normal time delay. When the bin fills with ice, the LOW BIN light goes out momentarily and the refrigeration and auger drive systems immediately shut down. (Note: The fan motor will continue to run for 10 minutes to cool condenser) The TIME DELAY light comes on, initiating the time delay period. When the time delay expires, the machine will restart provided that the LOW BIN light is on.

DIP Switch Settings

OFF POSITION ON POSITION

MCE425A/W_T, MCE425A/W_S, ER425A/W

OFF	ON		OFF	ON
1	<input checked="" type="checkbox"/>	[Sleep cycle disabled]	1	<input checked="" type="checkbox"/>
2	<input checked="" type="checkbox"/>	Not used	2	<input checked="" type="checkbox"/>
3	<input type="checkbox"/>	Not used	3	<input type="checkbox"/>
4	<input checked="" type="checkbox"/>	[Sleep cycle dispense duration]	4	<input checked="" type="checkbox"/>
5	<input checked="" type="checkbox"/>	20 min. time delay	5	<input checked="" type="checkbox"/>
6	<input checked="" type="checkbox"/>	Flush disabled	6	<input checked="" type="checkbox"/>
7	<input checked="" type="checkbox"/>	Maint. timer ON	7	<input checked="" type="checkbox"/>
8	<input checked="" type="checkbox"/>		8	<input checked="" type="checkbox"/>

NO

		[Sleep cycle enabled]		
		Not used		
		[Sleep cycle dispense duration]		
		60 min. time delay		
		Flush enabled		
		Maint. timer OFF		

DIP

425A/W installed in Symphony Plus 25/50/110 CI, CT, or FB

OFF	ON		OFF	ON
1	<input checked="" type="checkbox"/>	[Sleep cycle disabled]	1	<input checked="" type="checkbox"/>
2	<input checked="" type="checkbox"/>	Not used	2	<input checked="" type="checkbox"/>
3	<input type="checkbox"/>	Not used	3	<input type="checkbox"/>
4	<input checked="" type="checkbox"/>	[Sleep cycle dispense duration]	4	<input checked="" type="checkbox"/>
5	<input checked="" type="checkbox"/>	20 min. time delay	5	<input checked="" type="checkbox"/>
6	<input checked="" type="checkbox"/>	Flush disabled	6	<input checked="" type="checkbox"/>
7	<input checked="" type="checkbox"/>	Maint. timer ON	7	<input checked="" type="checkbox"/>
8	<input checked="" type="checkbox"/>		8	<input checked="" type="checkbox"/>

NO

		[Sleep cycle enabled]		
		Not used		
		[Sleep cycle dispense duration]		
		60 min. time delay		
		Flush enabled		
		Maint. timer OFF		

DIP

Replacement P425A/W installed in Symphony dispenser

OFF	ON		OFF	ON
1	<input checked="" type="checkbox"/>	[Sleep cycle disabled]	1	<input checked="" type="checkbox"/>
2	<input checked="" type="checkbox"/>	Not used	2	<input checked="" type="checkbox"/>
3	<input type="checkbox"/>	Not used	3	<input type="checkbox"/>
4	<input checked="" type="checkbox"/>	[Sleep cycle dispense duration]	4	<input checked="" type="checkbox"/>
5	<input checked="" type="checkbox"/>	20 min. time delay	5	<input checked="" type="checkbox"/>
6	<input checked="" type="checkbox"/>	Flush disabled	6	<input checked="" type="checkbox"/>
7	<input checked="" type="checkbox"/>	Maint. timer ON	7	<input checked="" type="checkbox"/>
8	<input checked="" type="checkbox"/>		8	<input checked="" type="checkbox"/>

NO

		[Sleep cycle enabled]		
		Not used		
		[Sleep cycle dispense duration]		
		60 min. time delay		
		Flush enabled*		
		Maint. timer OFF		

DIP

Sleep cycle dispense duration

OFF	ON		OFF	ON
4	<input checked="" type="checkbox"/>		4	<input checked="" type="checkbox"/>
5	<input checked="" type="checkbox"/>	35 s	5	<input checked="" type="checkbox"/>
4	<input checked="" type="checkbox"/>		4	<input checked="" type="checkbox"/>
5	<input checked="" type="checkbox"/>	15 s	5	<input checked="" type="checkbox"/>
4	<input checked="" type="checkbox"/>		4	<input checked="" type="checkbox"/>
5	<input checked="" type="checkbox"/>	5 s	5	<input checked="" type="checkbox"/>
4	<input checked="" type="checkbox"/>		4	<input checked="" type="checkbox"/>
5	<input checked="" type="checkbox"/>	60 s	5	<input checked="" type="checkbox"/>

* Flush can be enabled on Symphony CT and FB models. Flush should be disabled on Symphony CI units due to risk of internal leak if drain line is blocked. All Symphony Plus models should be set to Flush enabled.

Warranty Registration and Equipment Evaluation

Thank you for purchasing Follett® equipment. Our goal is to deliver high value products and services that earn your complete satisfaction by delivering high-value products and services backed by outstanding customer and technical support.

Please review the installation instructions thoroughly. It is important that the installation be performed to factory specifications so your equipment operates at its maximum efficiency.

Follett LLC will not be liable for any consequential damages, expenses, connecting or disconnecting charges, or any losses resulting from a defect of the machine. For full warranty details, visit our website www.follettice.com/productwarranties.

Registering your equipments helps Follett track your equipment's service history should you need to contact us for technical support, and your feedback helps us improve our products and services. Please visit www.follettice.com/support to complete the Warranty Registration form.

Should you have any questions, please contact Follett's technical support group at (877) 612-5086 or (610) 252-7301 and we will be happy to assist you.

Calgon is a licensed trademark distributed by Nu-Calgon, in the United States.

3M is a trademark of 3M Company.

SafeCLEAN, SaniSponge, and Symphony Plus are trademarks of Follett LLC.

Follett is a registered trademarks of Follett LLC, registered in US.



801 Church Lane • Easton, PA 18040, USA
Toll free (877) 612-5086 • +1 (610) 252-7301
www.follettice.com

Follett Europe Polska Sp. z o.o.
Mokry Dwór 26 c • 83-021 Wiślina, Poland
+48 (58) 785-6140 • Fax +48 (58) 785-6159
www.folletteurope.com



01083856R04
© Follett LLC 11/19